



# Commonwealth Utilities Corporation



## REQUEST FOR PROPOSALS

CUC-RFP-25-021

Independent Power Producer-Solar Photovoltaic with Battery Energy Storage System (BESS)  
for all Islands, CNMI

### **Question (RFI/C) No. 017: AP ENERGY LLC**

Date: September 26, 2025

\*\*\*\*\*

CUC provides the following responses to the Request for Information/Clarification (RFI/C):

1. What are the potential battery energy storage uses and technical requirements for Solar performance? Would Standalone BESS, DC Coupled, or AC Coupled BESS be preferred?
  - o Peak Shifting
  - o Solar supply smoothing
  - o Frequency services for the grid?

**CUC RESPONSE:** The Battery Energy Storage System (BESS) is expected to perform multiple grid-supporting functions, including peak load shifting, solar supply smoothing, and frequency and voltage regulation in accordance with CUC’s operational philosophy. The configuration type (Standalone, DC Coupled, or AC Coupled) is at the proponent’s discretion, provided that the system meets the technical performance, reliability, and grid-forming requirements set forth in the RFP. The proposed solution must demonstrate optimal system integration with the diesel generation fleet and future SCADA/grid controller architecture.

2. Is energy storage in the scope of all work or specific cases? As it does not fit in the definition given in section 7.4 of the technical proposal?

**CUC RESPONSE:** Yes, energy storage is within the scope of work as defined in the RFP. The PV+BESS system is an integrated solution, and the BESS component is required to ensure grid stability, load balancing, and operational reliability across Saipan, Tinian, and Rota. The System Integration Study will further refine system sizing and application based on each island’s generation and load profile.

3. Section 7.8 mentioned (“expected amount of downtime or outage time due to planned maintenance and unexpected forced outages”). Presumably, this is in reference to the specific equipment that we would build, however, will CUC provide more information regarding the



# Commonwealth Utilities Corporation



outages on the POC/Connection substations that they operate? As well as any curtailment at each proposed connection node.

**CUC RESPONSE:** CUC will provide available operational data regarding recent substation outages and curtailment history for the points of connection (POC) during the System Integration Study phase. Proponents should design their systems to minimize outage risks and ensure operational resilience. Curtailment, if necessary, will be coordinated through CUC's grid controller once implemented under the DOE Grid Resiliency and Modernization Program.

4. Section 7.8, how many days does CUC allow for downtime for standard maintenance and inspection overhauls?

**CUC RESPONSE:** CUC allows for reasonable planned maintenance downtime consistent with industry standards for renewable energy and energy storage systems. Proponents should include their maintenance schedule assumptions in the technical proposal. Final maintenance intervals and outage coordination will be approved by CUC during contract execution and commissioning planning.

5. Where is CUC's dedicated point of interconnection?

**CUC RESPONSE:** The point of interconnection (POC) will be defined for each island as part of the System Integration Study, based on proximity to existing CUC substations and the capacity of the transmission and distribution network. The tentative POC locations are near the existing power generation facilities on Saipan, Tinian, and Rota, as identified in the RFP and supporting appendices.

6. Will CUC provide information regarding POC voltage, headroom, and connection type?

**CUC RESPONSE:** Yes. CUC will make available the voltage level, available headroom, and connection configuration for each designated POC during the System Integration Study and interconnection design phase. This data will be shared with the selected proponent following contract award and execution of a confidentiality agreement.

7. Are proponents expected to detail the savings of their proposed solutions in comparison with the current cost of diesel fuel? If so, will details of the current cost of diesel fuel be provided?

**CUC RESPONSE:** Proponents are encouraged to present estimated cost savings and economic benefits compared to existing diesel generation. Proponents may use publicly available CNMI fuel cost data for initial analysis in their proposals. CUC will provide



# Commonwealth Utilities Corporation



reference diesel fuel pricing data to shortlisted proponents during the evaluation or negotiation phase.

8. Can proponents propose alternative forms of financial security (e.g., letters of credit or letters from the board confirming commitment of capital) instead of 100% bonds, or this requirement non-negotiable?

**CUC RESPONSE:** A Payment Bond of one hundred (100%) percent and a Performance Bond of one hundred (100%) percent of the total bid price will be required upon the execution of the contract by the selected proponent. This requirement is not negotiable.

9. Can proponents propose alternative forms of financial security (e.g., letters of credit or letters) to support Audited Financial Statements, or is this requirement non-negotiable?

**CUC RESPONSE:** The requirement for audited financial statements is mandatory and non-negotiable. CUC requires this documentation to verify the financial standing and creditworthiness of proponents. However, supplementary documentation such as letters of credit or parent company guarantees may be submitted in addition to the audited financial statements for additional support.

10. If a proponent submits multiple projects (e.g., different islands or different system sizes), can the Cost Proposal be consolidated for economies of scale, or must each project have a fully separate cost submission?

**CUC RESPONSE:** If a proponent submits multiple proposals, for example one proposal per island, then each island's proposal must have a separate and complete Cost Proposal, as outlined in the RFP. However, proponents may note any shared cost advantages or economies of scale in their submissions. CUC may consider these efficiencies during the evaluation process if clearly identified and justified.

11. If project timelines are delayed due to permitting, CUC approvals, or force majeure (e.g., typhoons), how will CUC treat schedule compliance obligations?

**CUC RESPONSE:** CUC will equitably consider delays resulting from force majeure events, permitting delays, or CUC review processes, in accordance with the terms of the executed Power Purchase Agreement (PPA). Time extensions may be granted upon written justification and documentation submitted by the proponent and reviewed by CUC.



# Commonwealth Utilities Corporation



12. Will CUC or the CNMI government assist with permitting, environmental clearances, and land-use approvals, or must proponents manage these entirely?

**CUC RESPONSE:** Proponents are responsible for obtaining all required permits, environmental clearances, and land-use approvals. CUC and the CNMI government agencies (e.g., DPL, DEQ, Zoning, CPA) will provide coordination and endorsement letters as needed but will not serve as the primary permit applicant.

13. Could we get a copy of the current draft Power Purchase Agreement template? Please include any dispute resolution terms if they have already been drafted.

**CUC RESPONSE:** Refer to Appendix E: Form Contract. The current Form Contract in Appendix E serves as a template and will be modified during contract negotiations. Proponents should expect changes to Appendix E reflecting the final PPA framework, performance standards, and payment terms, among other things, prior to contract execution.

14. If the buyer under the PPA agreement fails to meet their obligations, what authority or dispute resolution mechanism will handle such conflicts?

**CUC RESPONSE:** Refer to Appendix E: Form Contract, Article 12, Section O(vi) – Contract Disputes (page 12 of 15 of the Form Contract).

15. Could we get a single-line diagram for the transmission lines for Saipan, Tinian, and Rota?

**CUC RESPONSE:** The single-line diagrams for Saipan, Tinian and Rota are attached at the end of this document.

16. How does the Office of Grants, which is charged with supplanting/supplementing RE to government offices, affect the current capacity of CUC? Ex. [if] OGM takes all government offices, Hospital, and major government infrastructure off the CUC grid, how will this affect the PPA?

**CUC RESPONSE:** The Office of Grants Management's (OGM) renewable energy initiatives are complementary to CUC's overall grid and do not alter CUC's mandated responsibility as the sole public utility serving the CNMI. Any additional distributed renewable systems implemented under OGM will be integrated into CUC's overall energy portfolio. The PPA will remain governed by CUC's total system demand and energy balancing requirements, and not by individual customer load transfers.



# Commonwealth Utilities Corporation



17. CUC's current capacity is below the current Solar PPA MW and MWh requirements. Will CUC purchase all power produced by the Proponent? Ex. IPP produces 60MW, will CUC purchase all 60MW produced?

**CUC RESPONSE:** CUC will purchase energy delivered up to the contracted capacity and within the grid's operational limits, as defined in the RFP. Any excess generation beyond the allowable injection limit or system demand may be subject to curtailment, which will be coordinated through the grid controller and SCADA system to maintain grid stability and reliability.

18. Given that the combined capacity of the proposed solar PV and BESS system is significantly higher than the existing Saipan grid capacity, could you please clarify how the grid limit will be applied? Specifically, should we design the system to cap the injection at the stated grid limit, or is there flexibility to utilize the BESS to absorb excess generation beyond that limit?

**CUC RESPONSE:** Proponents must design the PV+BESS system to respect the defined grid injection limits for each island. However, BESS may be used to absorb excess solar generation beyond the grid's immediate capacity, subject to coordination through the System Integration Study and CUC's grid controller operating parameters. The control strategy must prevent grid overloading while maximizing renewable energy utilization.

19. What is the exact scope of work for CUC's grid improvements needed for interconnection and integration? This is an unknown factor that requires further information for the RFP response.

**CUC RESPONSE:** The System Integration Study, which will be coordinated and funded by the developer under this RFP, will determine additional upgrades required for renewable energy integration.

20. Could you please provide details about the existing SCADA system currently used by CUC? In particular, we would like to know the platform, communication protocols, and integration requirements that we should consider when planning any upgrades or interfaces for the proposed PV and BESS project.

**CUC RESPONSE:** Currently, CUC does not operate a fully integrated SCADA system. Each island functions independently with manual or limited local monitoring at the power plants. CUC is in the process of procuring and implementing a unified SCADA platform under the DOE Grid Resiliency and Modernization Grant Program, which will standardize communication protocols, control interfaces, and integration requirements. Details of the



# Commonwealth Utilities Corporation



SCADA architecture, protocols (e.g., Modbus, DNP3, or IEC 61850), and integration standards will be provided to the selected proponent following system commissioning and during the integration design phase.

A handwritten signature in blue ink that reads "Kevin O. Watson".

**KEVIN O. WATSON, MPA**

Executive Director

Commonwealth Utilities Corporation

**\*\*\*END OF RFI/C Response No. 017\*\*\***



# Commonwealth Utilities Corporation



## SAIPAN SINGLE LINE DIAGRAM

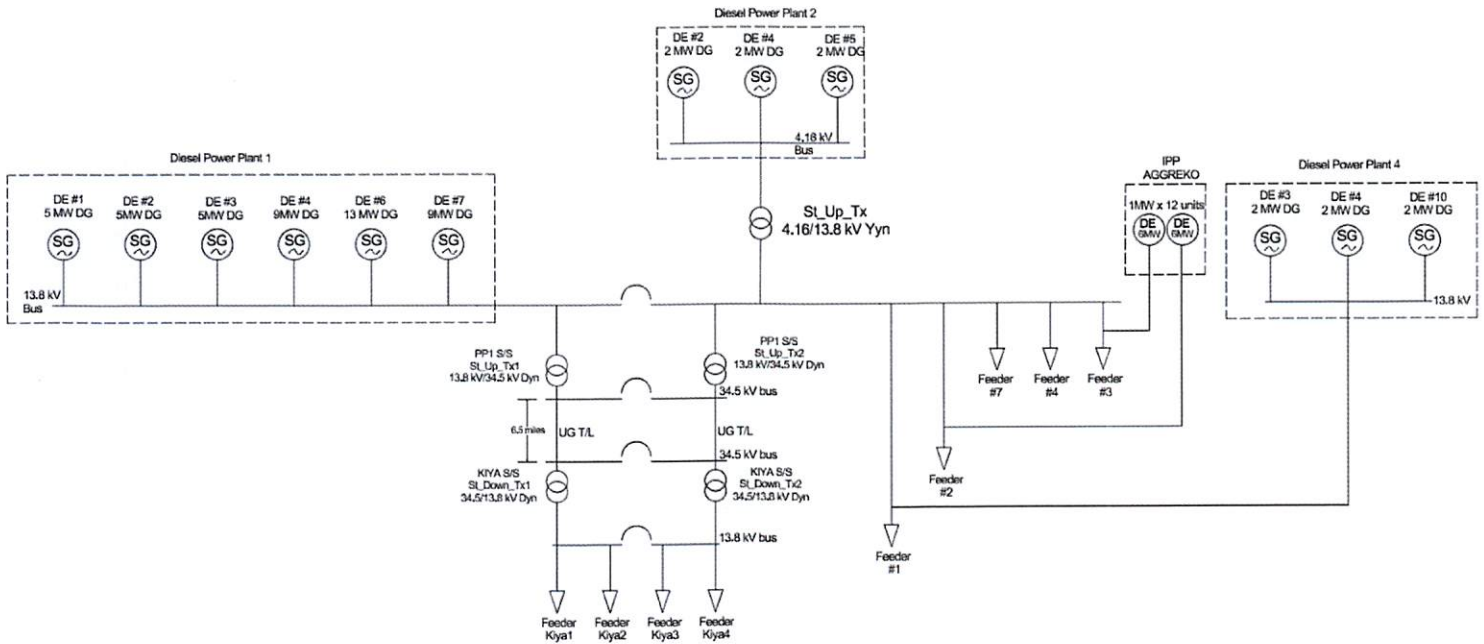



# Commonwealth Utilities Corporation



## TINIAN SINGLE LINE DIAGRAM

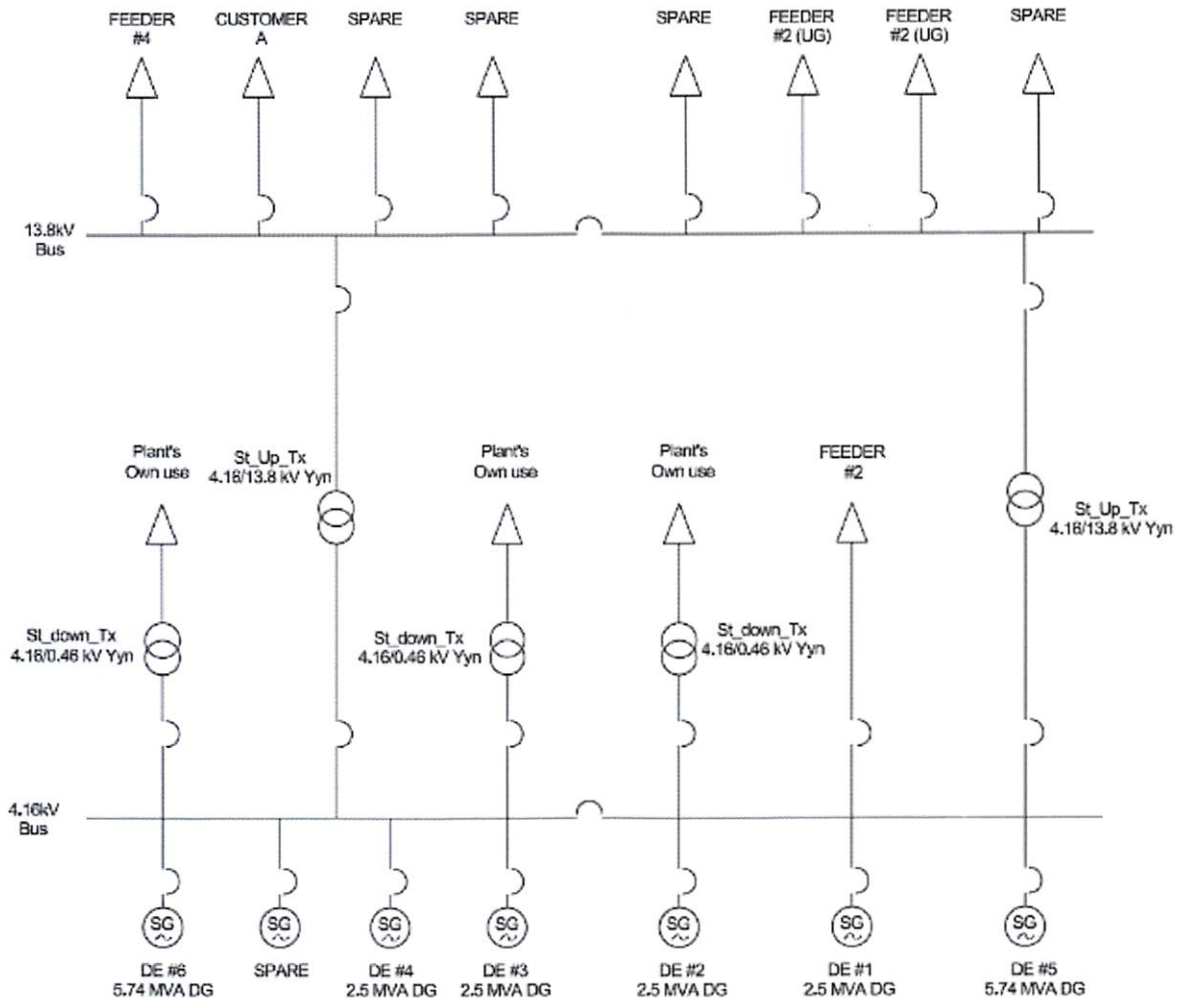



## ROTA SINGLE LINE DIAGRAM

